

EE 230
Experiment 7
Fall 2006

Nonlinear Operational Amplifier Applications

Objectives: The primary objective of this experiment is to investigate some nonlinear applications of operational amplifiers. A second objective will be to develop systematic design strategies that combine several circuits that have been investigated separately throughout this course.

Equipment:

Computer with SPICE, Signal Express, GP-IB capability, and appropriate IVI drivers
HP E3631A or equivalent power supply (GP-IB Capable)
HP 33120A or equivalent signal generator (GP-IB Capable)
HP 34401A or equivalent multimeter (GP-IB Capable)
HP 54602B or equivalent oscilloscope

Parts:

Assortment of Resistors and Capacitors
3 741 op amps
Potentiometer
Amplified speaker
2 Photoresistors

Practical Details: The operational amplifier is widely used to build useful linear circuits. It has been observed, however, that when the input of most commercial operational amplifiers is over-driven, they perform in a very predictable way and if over-driven in certain ways, the over-drive does not destroy the amplifier. Over-driven operational amplifiers can be used to create a large variety of very useful nonlinear systems.

When the input is over-driven, the null-port property of the operational amplifier is lost. How a device performs when it is over-driven depends upon the type of amplifier and on the specific architecture and components used to build the op amp.

The 741 and a large number of other operational amplifiers, when over-driven at the input port, will exhibit the transfer characteristics shown in Fig. 1.

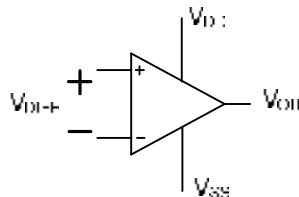

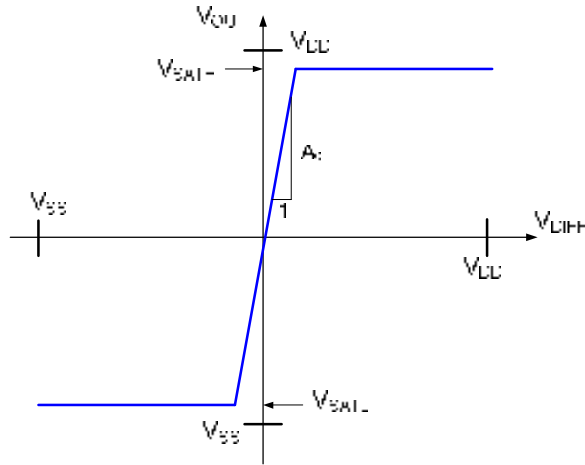

Fig. 1 Transfer Characteristics of Operational Amplifier Showing Saturation

The slope of the transfer characteristics is the dc gain of the operational amplifier and is generally very high and much steeper than what is depicted in Fig. 1. The high and low saturation voltages, V_{SAT+} and V_{SAT-} , are often very close to V_{DD} and V_{SS} respectively. Thus, a good approximate model for the operational amplifier when operated with a significant overdrive in the input is shown in Fig. 2.

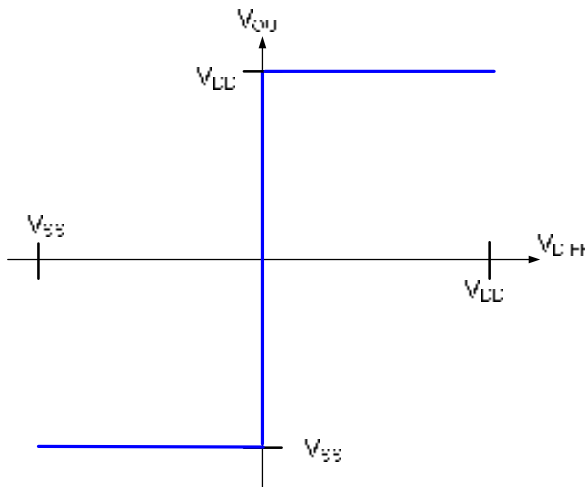

Fig. 2 Nonlinear Operational Amplifier Transfer Characteristics

Although the differential voltage at the input port of the op amp will not be zero when operated nonlinearly, the input current at both input terminals is still nearly zero for many commercial op amps and we will limit our discussion of nonlinear op amp applications to those op amps that have this property. Thus, we can summarize the nonlinear model for the operational amplifier with the set of equations:

$$V_{OUT} = \begin{cases} V_{DD} & V_{DIFF} > 0 \\ V_{SS} & V_{DIFF} < 0 \end{cases}$$

$$I^+ = I^- = 0$$

where I^+ and I^- are the input currents to the positive and negative terminals of the operational amplifier.

A basic noninverting comparator built with an operational amplifier is shown in Fig. 3a and a basic inverting comparator in Fig. 3b. These both compare the input signal relative to ground providing either a high or low output depending upon whether the input is positive or negative.

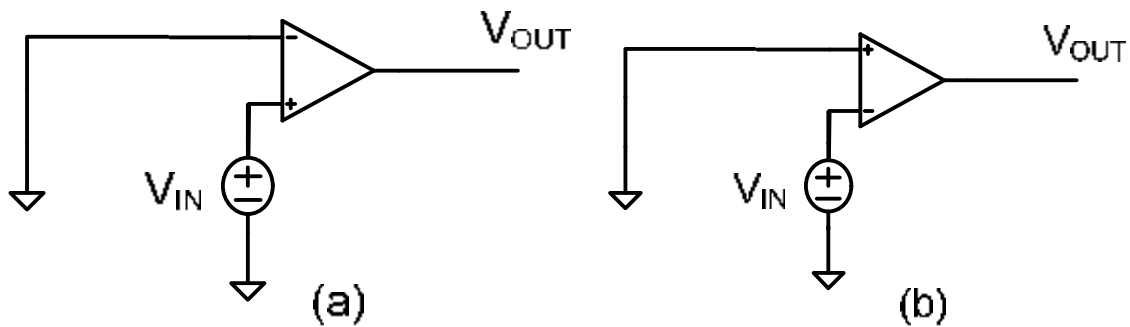

Fig. 3 Basic Op-Amp Based Comparators

The comparator function is so important that a class of “amplifiers” that are designed to work as nonlinear elements such as shown in Fig. 3 are available. These are appropriately termed “Comparators”. Most circuits sold as comparators will not work well or at all in linear applications but those circuits sold as comparators often perform better than op amps in some respects one of which is usually slew rate. In this experiment we will use op amps as comparators.

Often comparators must make a comparison of an input with respect to some voltage other than ground or require hysteresis to provide some region around the transition point where small changes in the input will not cause repeated changes in the output. Numerous minor modifications of the circuits in Fig. 3 can be used to provide these properties. Two such circuits are shown in Fig. 4.

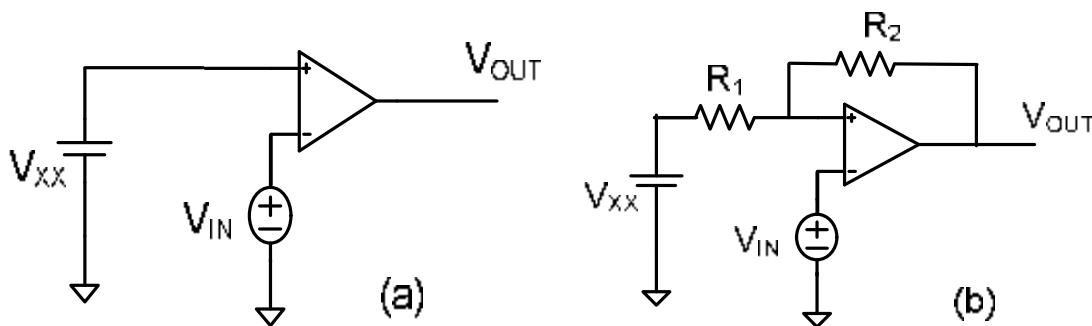

Fig. 4 Modified Comparators (a) with trip-point control (b)with hysteresis and trip-point control

Essentially all of the circuits that have been considered in the laboratory portion of the course up to this point have focused on how an output of the circuit responds to a given input. In this section we will consider a circuit that has no input but still has a

useful output waveform. Such circuits are widely used for generating waveforms such as sine waves, triangle waves, and square waves. The circuit shown in Fig. 5 is one such circuit. It is actually a variant of the comparators shown in Fig. 1 in which a feedback signal is applied to the noninverting terminal as well.

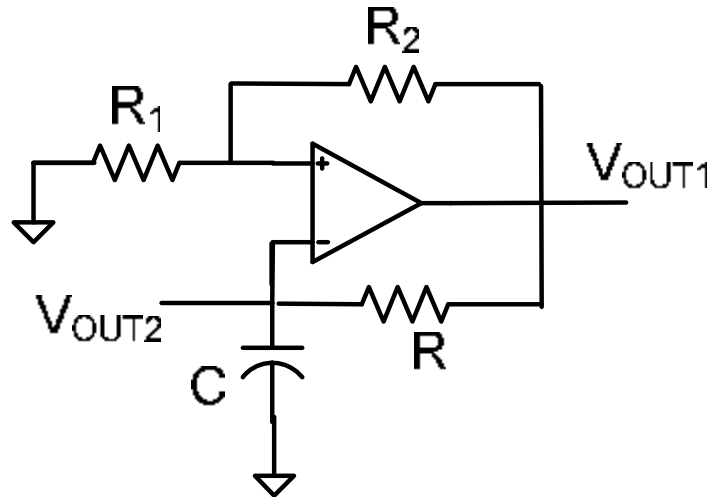

Fig. 5 Waveform Generator Circuit

When discussed in class, it was observed that the output V_{OUT1} was a square wave and thus this circuit was termed a square-wave generator. In the analysis presented, however, it was also observed that V_{OUT2} looked much like a triangle wave. This can also be considered as an output but a buffer may be needed if V_{OUT2} is to drive other circuits that do not have an infinite input impedance. The magnitude of the triangle wave could be readily modified if instead of connecting a buffer on V_{OUT2} , a noninverting amplifier were used.

Part 1 Build a Comparator

- 1) Design and test a comparator that has an output of 12V when $V_{IN} > 1V$, an output that is -12V when $V_{IN} < -1V$, and that has a hysteresis window for $-1V < V_{IN} < 1V$. When testing the input, apply a triangle waveform with p-p value of 10V to show directly the hysteresis region.
- 2) Design a circuit that will provide a pulse waveform on the output when an audio frequency triangular waveform is provided on the input in which the pulse width can be adjusted with a single resistor.

Part 2 Build a Waveform Generator

- 1) Design and test a square-wave generator that has an output frequency of approximately 1 kHz.

(Save the second half of Part 2 until the end of the period and do if time permits.)

- 2) A variant of the waveform generator is shown in Fig. 6. in which a diode and a second feedback resistor have been added to the circuit. This is also a waveform generator. Describe how this circuit is supposed to perform and verify experimentally. You may assume the diode is ideal in your analysis.

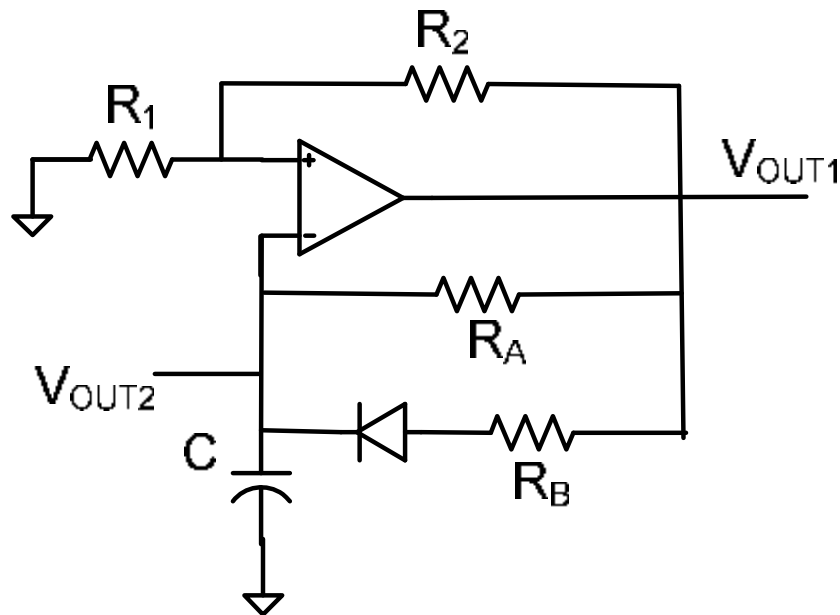

Fig. 6 Another Waveform Generator

Part 3 “Musical” Instrument Design

In 1919, Léon Theremin of Russia introduced a musical instrument that had three properties that were distinct to music in the western world. The instrument was electronic, the instrument did not have discrete notes as are common in most western-world instruments, and the musician did not physically touch the instrument to play it. Such an instrument created considerable excitement and interest throughout the western world and the sounds Theremin was able to produce were unlike anything people had heard before. His instrument was called a Theremin. Many instruments have evolved since that time with the same three properties and such instruments are often referred to as Theremins as well. The impact the Theremin itself ultimately had on the music industry was limited although there is still some use of devices similar to that initially introduced. Theremin’s impact on the music community, however, was much broader than the “Theremin”. His concept of electrically generating sounds that were unlike anything that could be generated with conventional musical instruments is often viewed as the beginning of the era of the music synthesizer which is extensively used throughout the music and movie industry today.

With the broad definition of a Theremin as being one that has no discrete notes, the musician has no physical contact, and the sound is generated electronically, your task will be to build a Theremin as part of this laboratory.

Some insight into how this can be approached may be gained by considering the following circuit

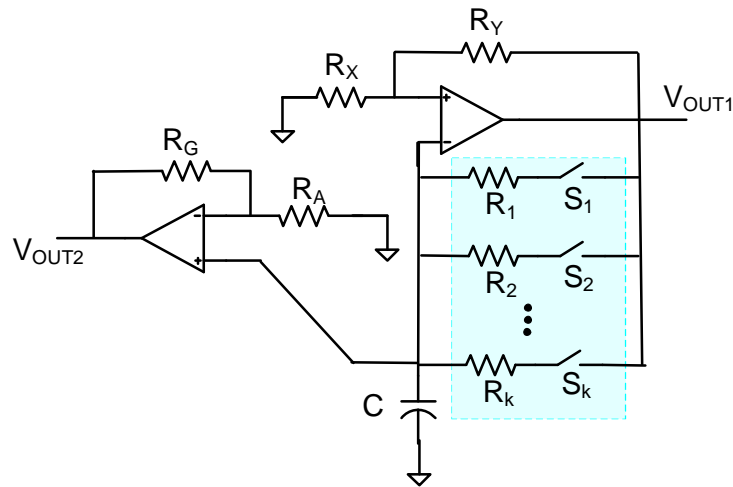

Fig. 7 Discrete-Note Synthesizer

This is simply the waveform generator of Fig. 5 where the resistor R that is used to determine the frequency is replaced by a set of discrete resistors as indicated in the shaded box in this figure. If the values of the resistors are appropriately chosen or trimmed and the switches are made with SPST momentary devices, the switch array could be considered a keyboard and this instrument would play discrete notes with nearly triangle wave-shape coming out of V_{OUT2} and with nearly square wave-shapes coming out of V_{OUT1} . The resistor R_G , if made variable with a potentiometer, could be viewed as a volume control for the triangular output. If the resistor R in Fig. 5 (or the resistor array in Fig. 7) were replaced with a variable resistor, the frequency of the outputs V_{OUT1} and V_{OUT2} would vary continuously with the resistor value. Details about the Theremin you are to build follow.

- 1) Build and demonstrate through a speaker a Theremin that has the following properties. The output is to be the sum of two triangle waves. The instrument is to be played without any physical contact to the circuit by using your hands to modulate the amount of light striking the circuit. Each triangle waveform should be independently controllable between approximately 400 Hz and 1.2 kHz by the amount of light striking it (it is important that you limit the frequency adjustment range to approximately that specified – in this case, more is not better).
- 2) Demonstrate to your TA that you have met the 400 Hz to 1.2 kHz adjustment range and demonstrate the audio output you obtain by adding the two triangle outputs. By moving your hands in the appropriate way, the frequency of the two triangle waveforms can be nearly the same or can be significantly different.
- 3) **(Optional)** Add a third and fourth optical controls to your Theremin in which the relative mix of the two waveforms and the overall output amplitude is varied. If the latter functionality is added, it may take two people to “play”

the instrument unless you have considerable dexterity or creativity in controlling 4 degrees of motion with your body.